



Heat Driven Cooling: Absorption Closed Cycles and Machines

January 2010

Yunho Hwang, Ph.D.

**Center for Environmental Energy Engineering
Department of Mechanical Engineering
University of Maryland
College Park, MD 20742-3035**

Solar Cooling Options

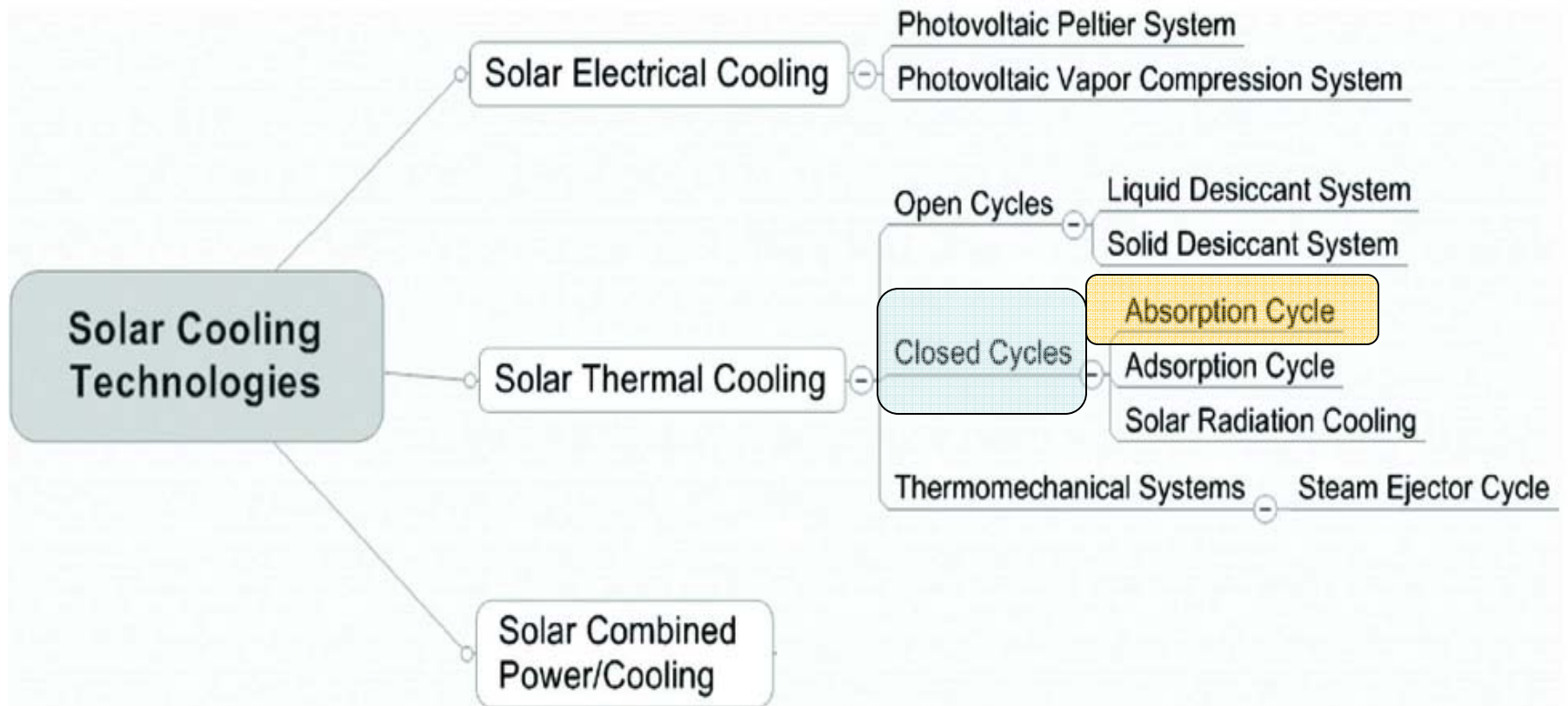

Introduction

- The *Absorption Cycle* was invented in 1846 by *Ferdinand Carré* for the purpose of *producing ice with heat input*.
- The absorption cycle enjoyed widespread use from the 1920's as *gas powered refrigerators/ice-makers*.
- It is based on the principle that *absorbing ammonia in water causes the vapor pressure to decrease*.
- The *lithium bromide solution* (a very strong absorbent of water) *absorbs the surrounding water vapor* from the evaporator continuously and keeps the low-pressure condition.

Introduction

- Absorption cycles *produce cooling and/or heating* with *thermal input and minimal electric input*, by using heat and mass exchangers, pumps and valves.
- An absorption cycle can be viewed as a *chemical vapor-compression cycle*, with the *compressor replaced by a generator, absorber and liquid pump*.

Working Fluids

- The working pair (liquid/vapor) is made up of a *refrigerant* and a *solution* which absorbs the refrigerant.
- *Working pairs* include:
Ammonia / Water & *Water / Lithium-bromide*
- $H_2O/LiBr$ (refrigerant/solution):
 - Absorbent has high B.P. (vapor: almost pure H_2O)
 - Can be in solid phase in operating range
 - Refrigeration temp. is limited by freezing point of H_2O
- NH_3/H_2O (refrigerant/solution):
 - Vapor contains both NH_3 and H_2O > need rectifier
 - High vapor pressure
 - Toxic

Working Fluids

Refrigerant/ Absorbent	H₂O/LiBr	NH₃/H₂O
Operating pressures	Low	High
COP	COP 0.7	COP 0.5
Limitation	Freeze: T_{evap} > 0°C Crystallization: T_{abs} < 40°C	Need rectifier Does not freeze Toxic
Application	Air conditioning	Refrigeration

Vapor Compression Cycle

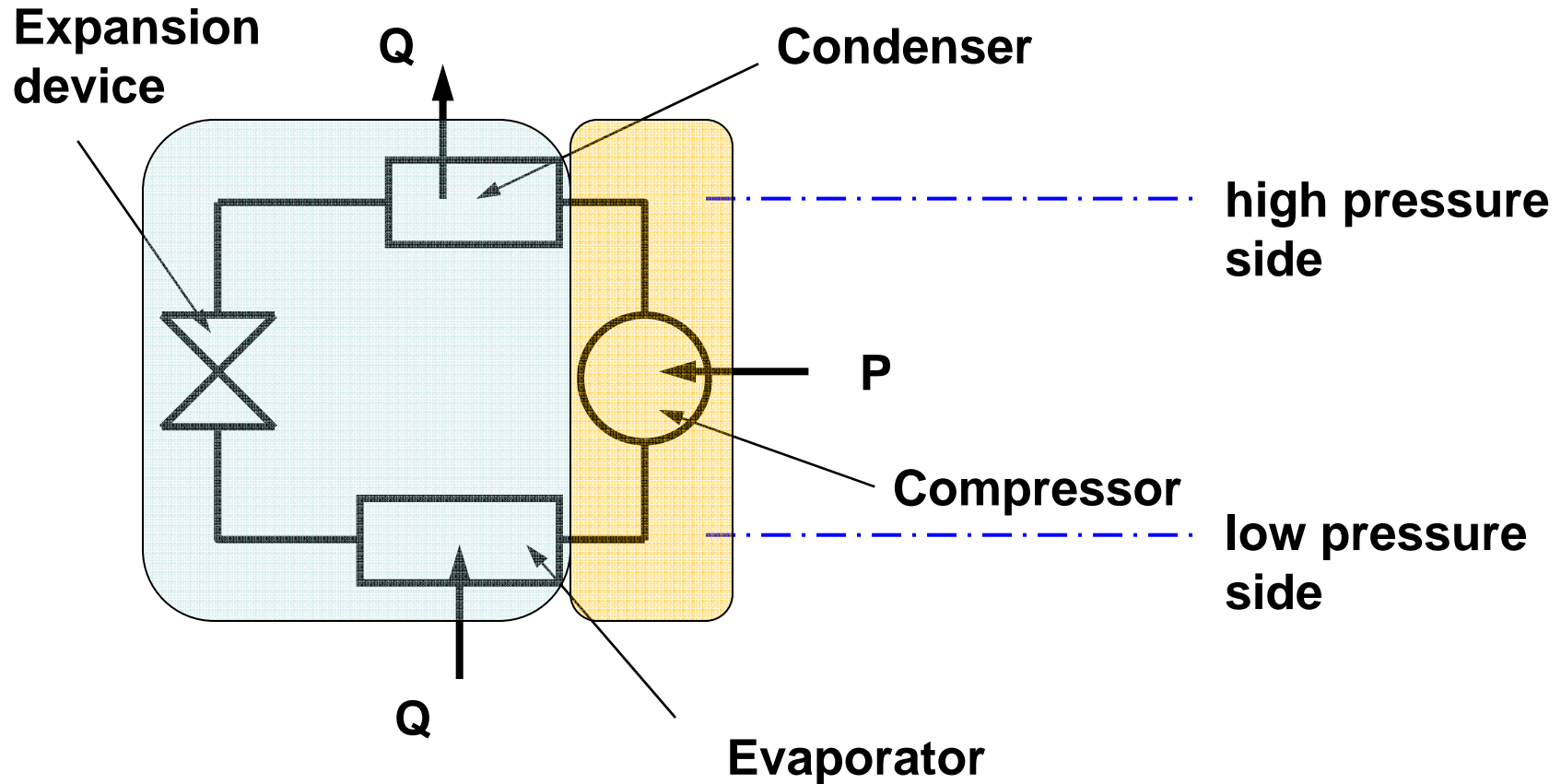

All 4 components have the same mass flow rate.

Absorption Cycle: H₂O/LiBr

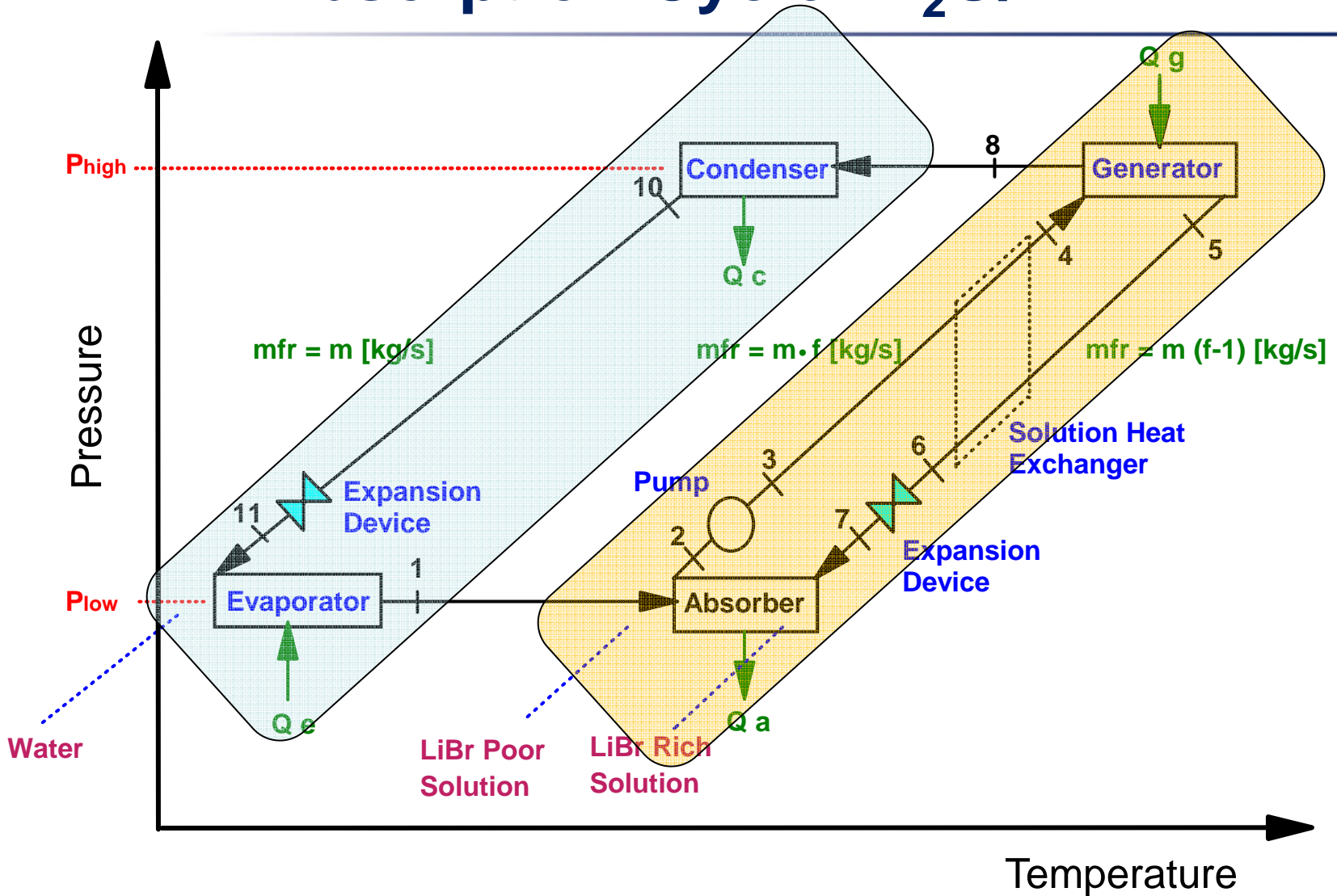

Absorption Cycle

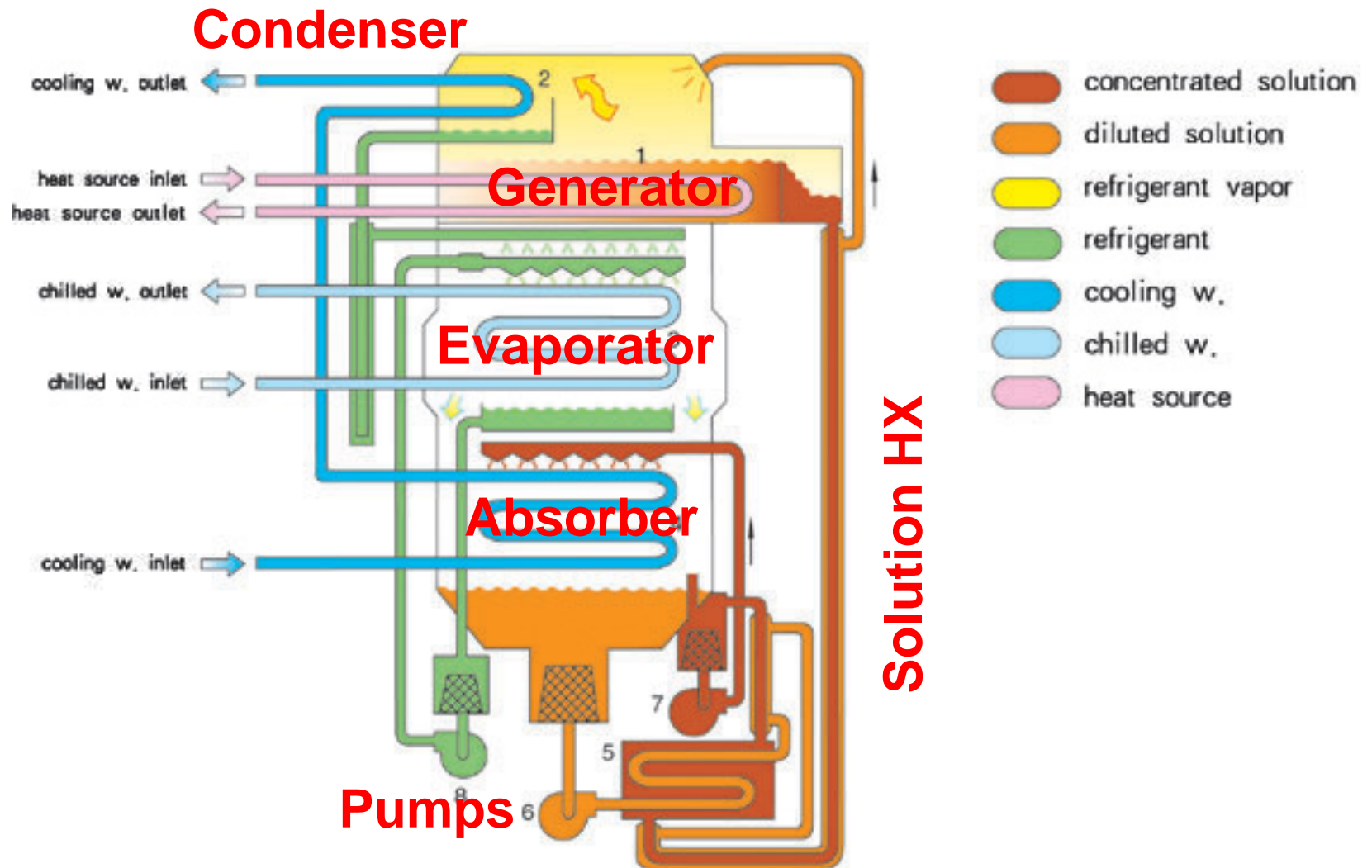

Basic Operation of H₂O/LiBr Cycle

- **Generator:**
 - Heat is added to re-vaporize the water from a diluted H₂O/LiBr solution.
 - The concentrated LiBr solution returns to the absorber
 - The water vapor migrates to the condenser
- **Condenser:**
 - The high pressure water vapor flows to a condenser, typically cooled by the cooling tower.
- **Evaporator:**
 - By creating a 6 mmHg pressure condition in an airtight vessel, water can even evaporate at 4°C (39°F).

Basic Operation of H₂O/LiBr Cycle

- **Absorber:**
 - The lithium bromide solution absorbs the vapor (transferring the heat of absorption to cooling water) in a diluted solution.
 - A diluted solution is pumped to a higher pressure.

Working Fluids- NH₃/H₂O

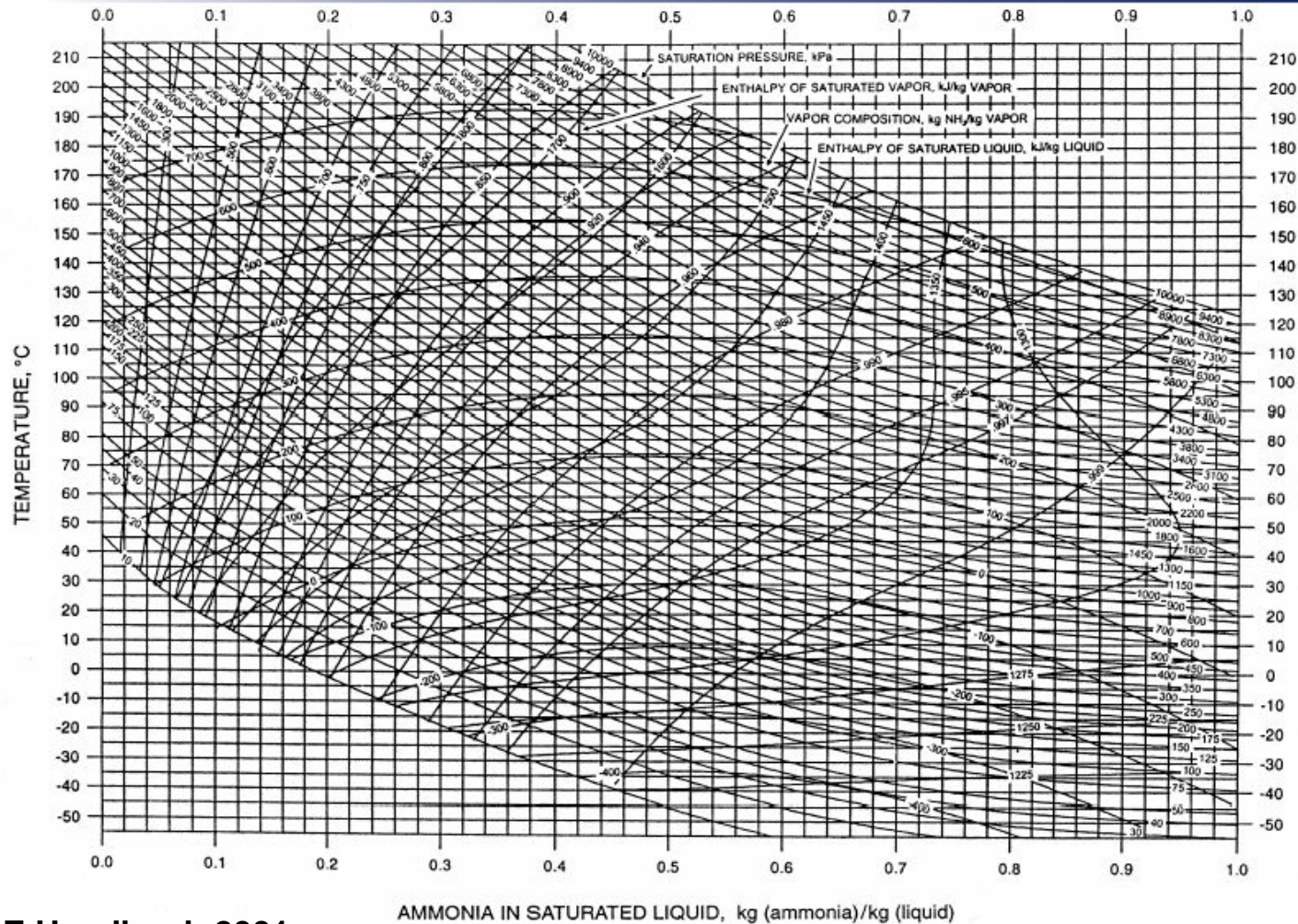

Source: ASHRAE Handbook-2001

Fig. 29 Enthalpy-Concentration Diagram for Ammonia-Water Solutions

Prepared by: Kwang Kim and Keith Herold, Center for Environmental Energy Engineering, University of Maryland at College Park

Working Fluids - H₂O/LiBr

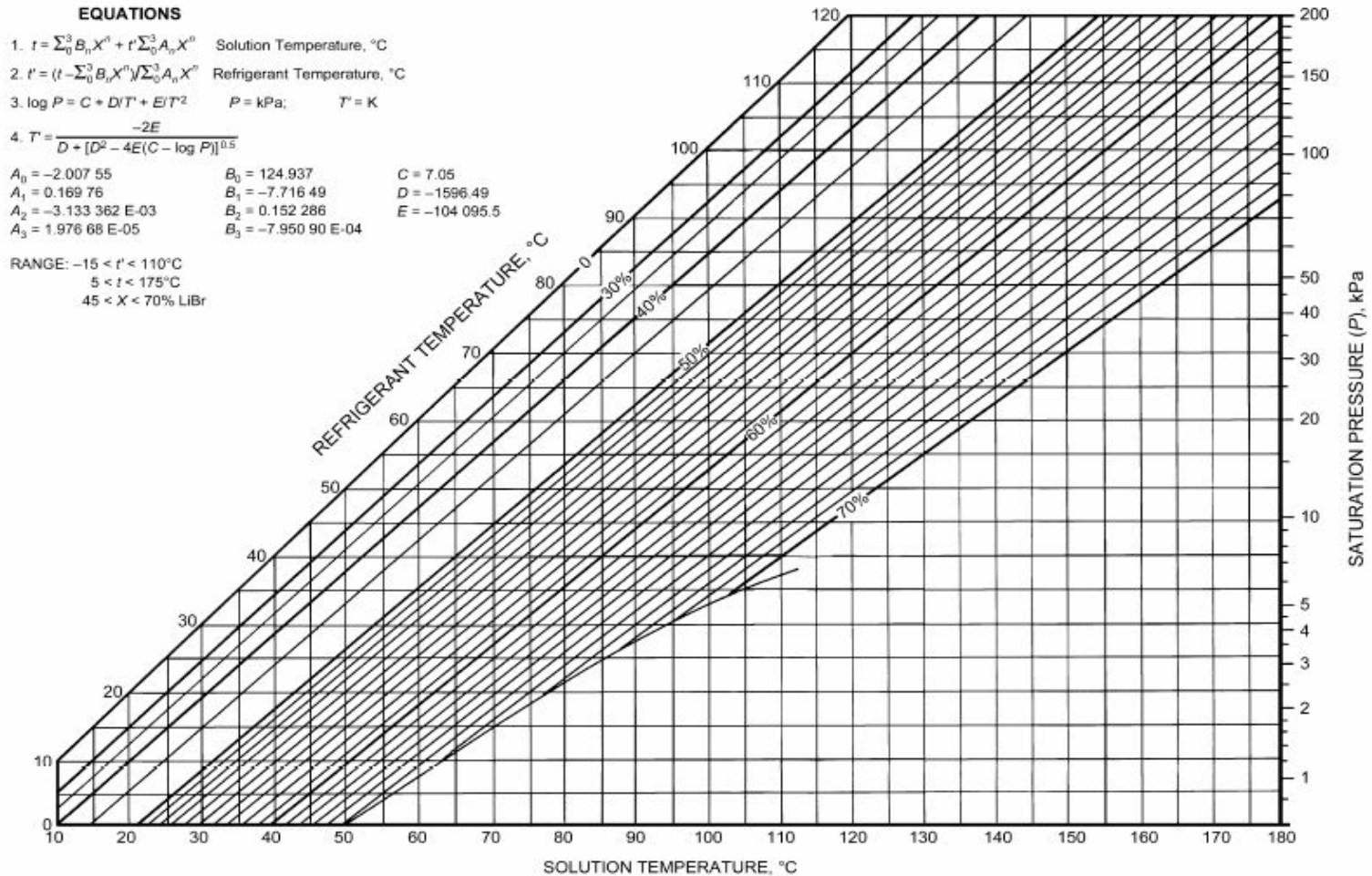

Source: ASHRAE Handbook-2001

Fig. 31 Equilibrium Chart for Aqueous Lithium Bromide Solutions
 Reprinted by permission of Carrier Corp.

Absorption Cycle: H₂O/LiBr

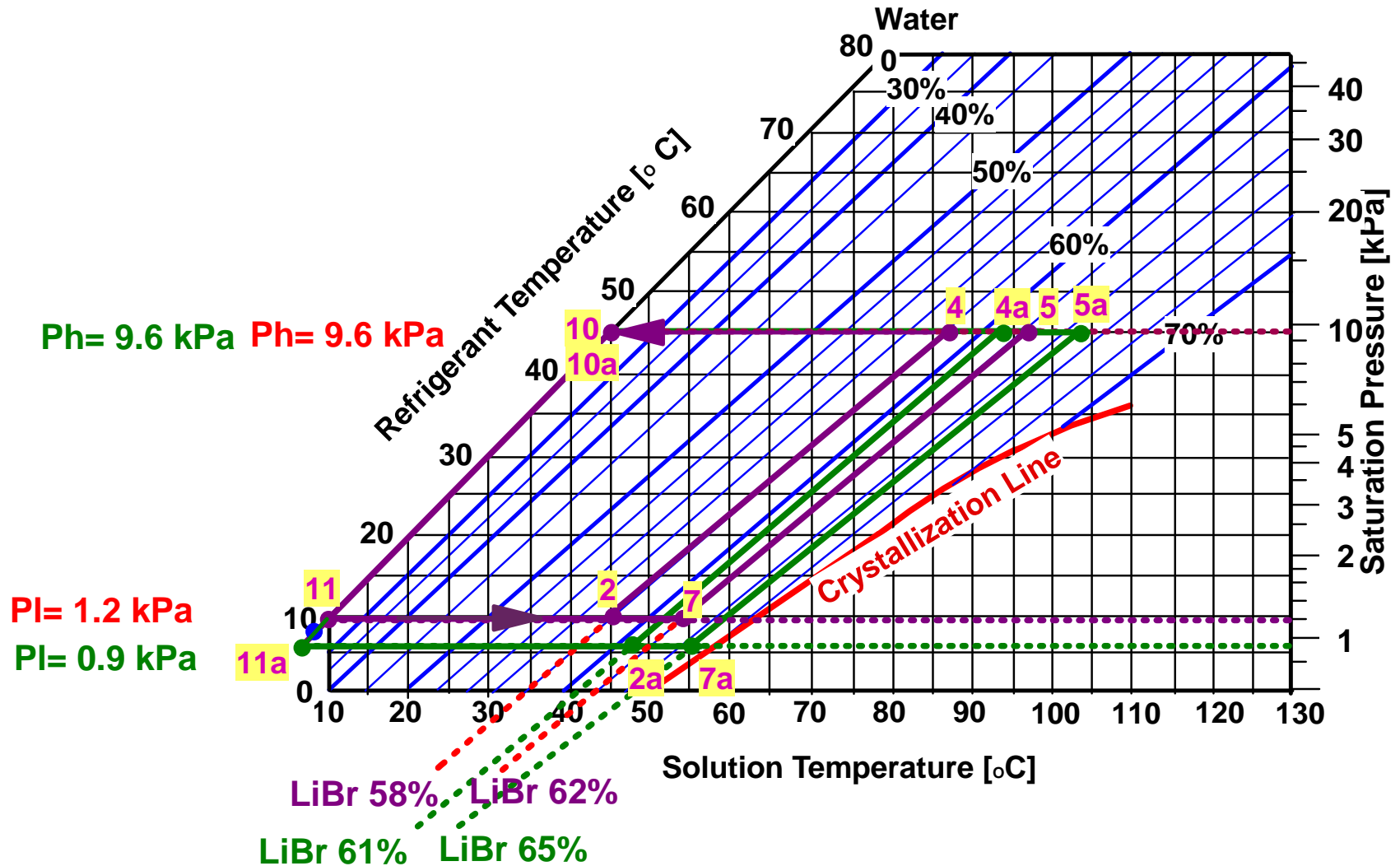

Absorption Cycle: H₂O/LiBr

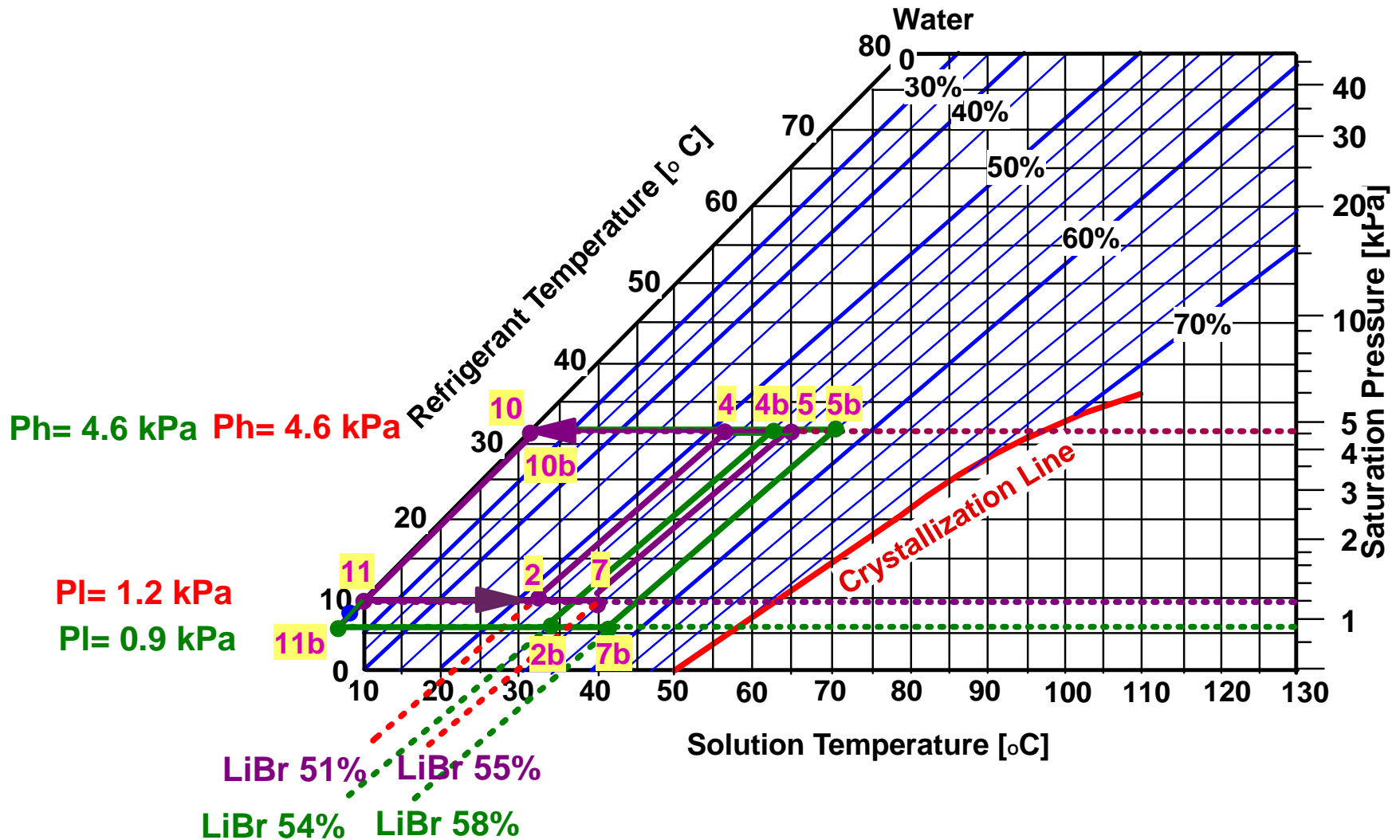

Efficiency Enhancement (H₂O/LiBr)

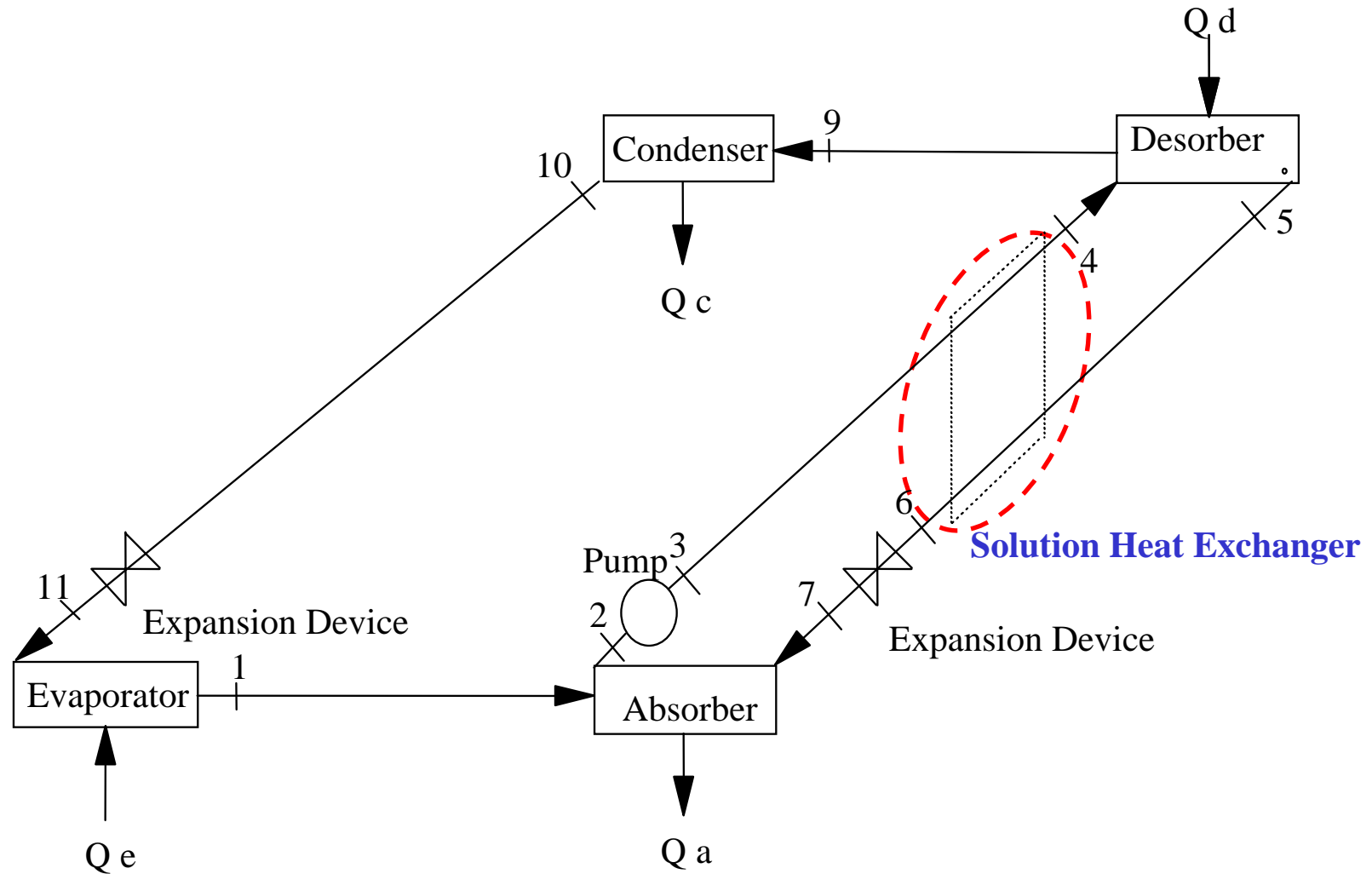

Efficiency Enhancement (NH₃/H₂O)

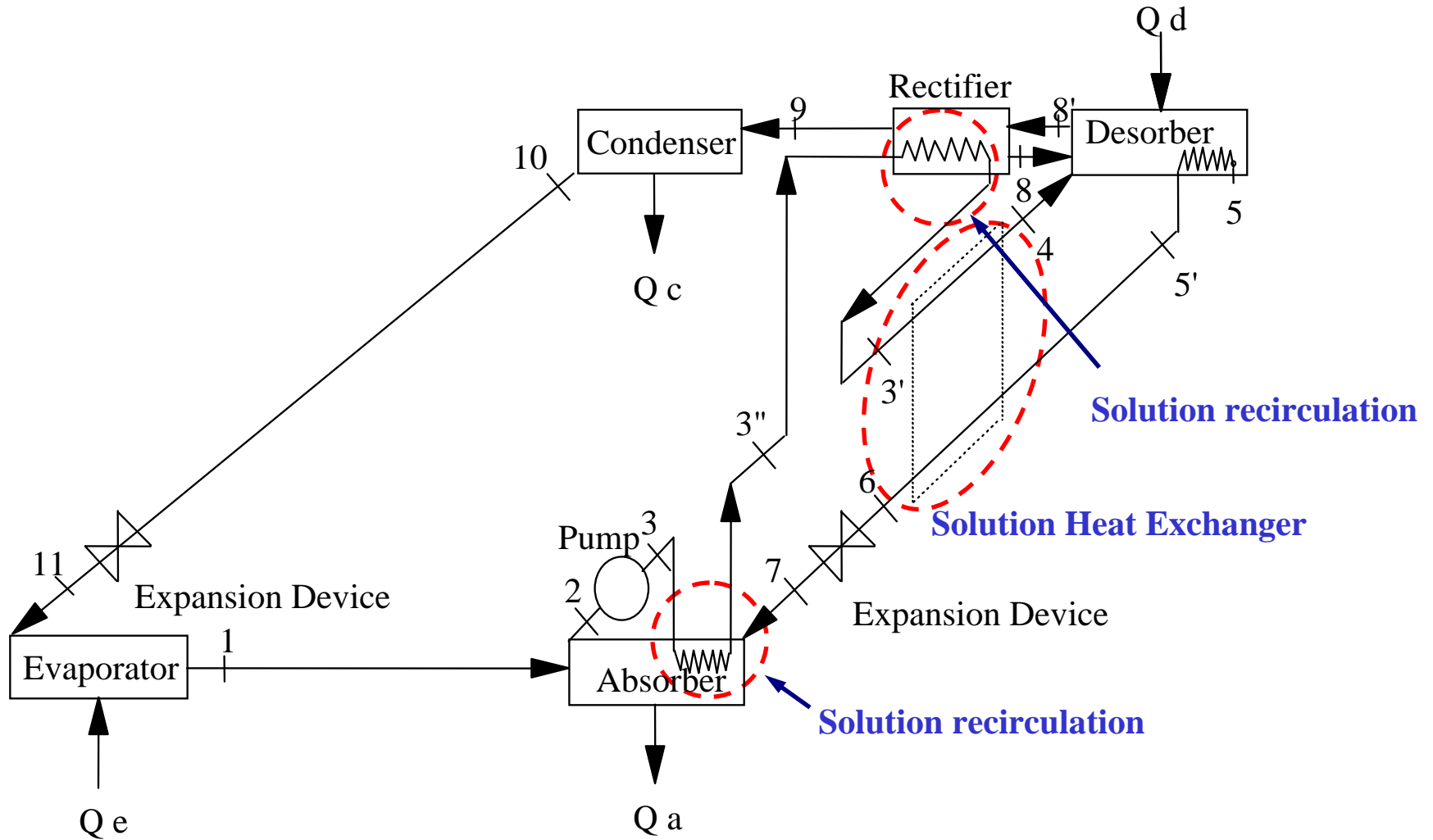

Absorption Chiller Model

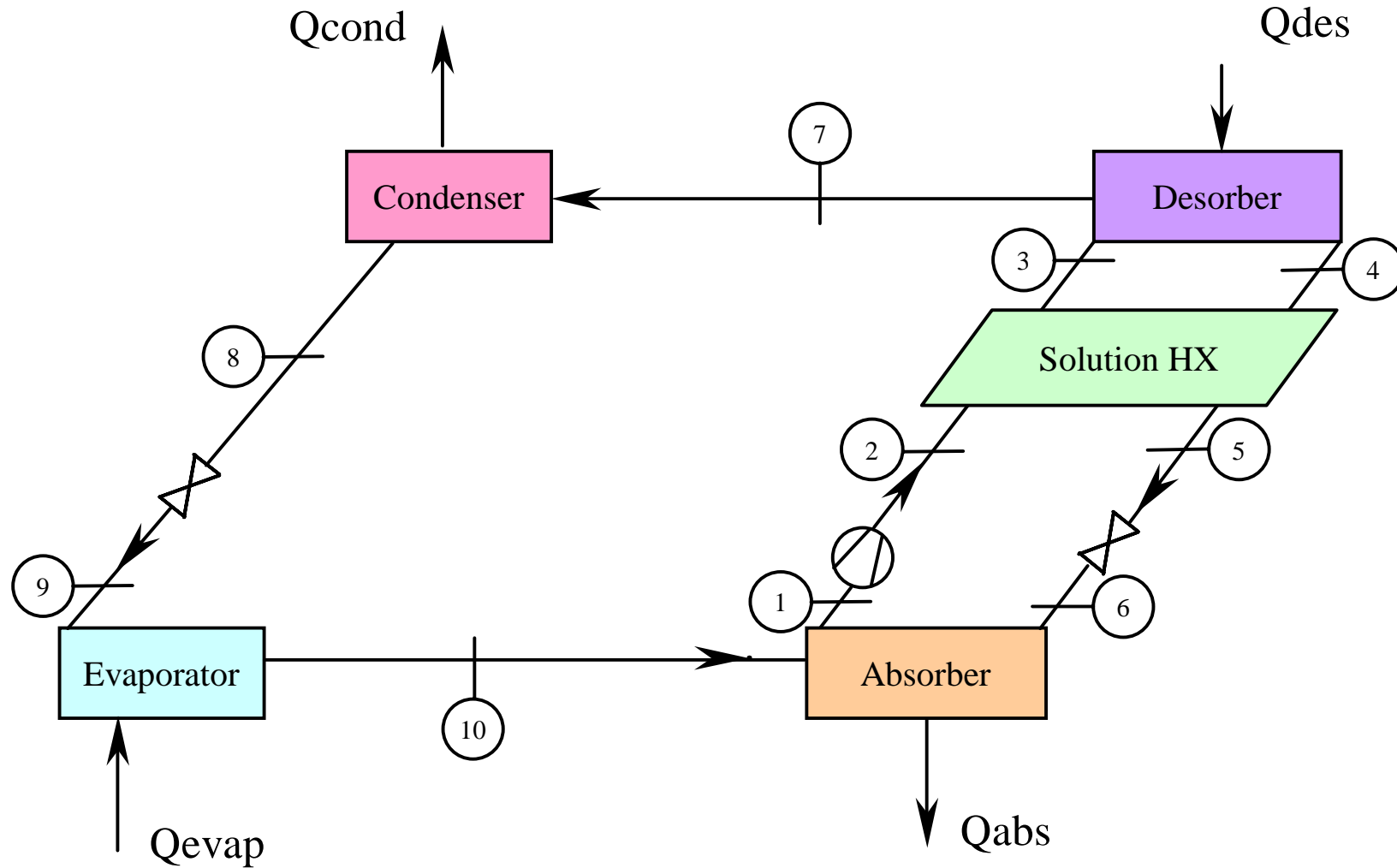

Absorption Chiller Model

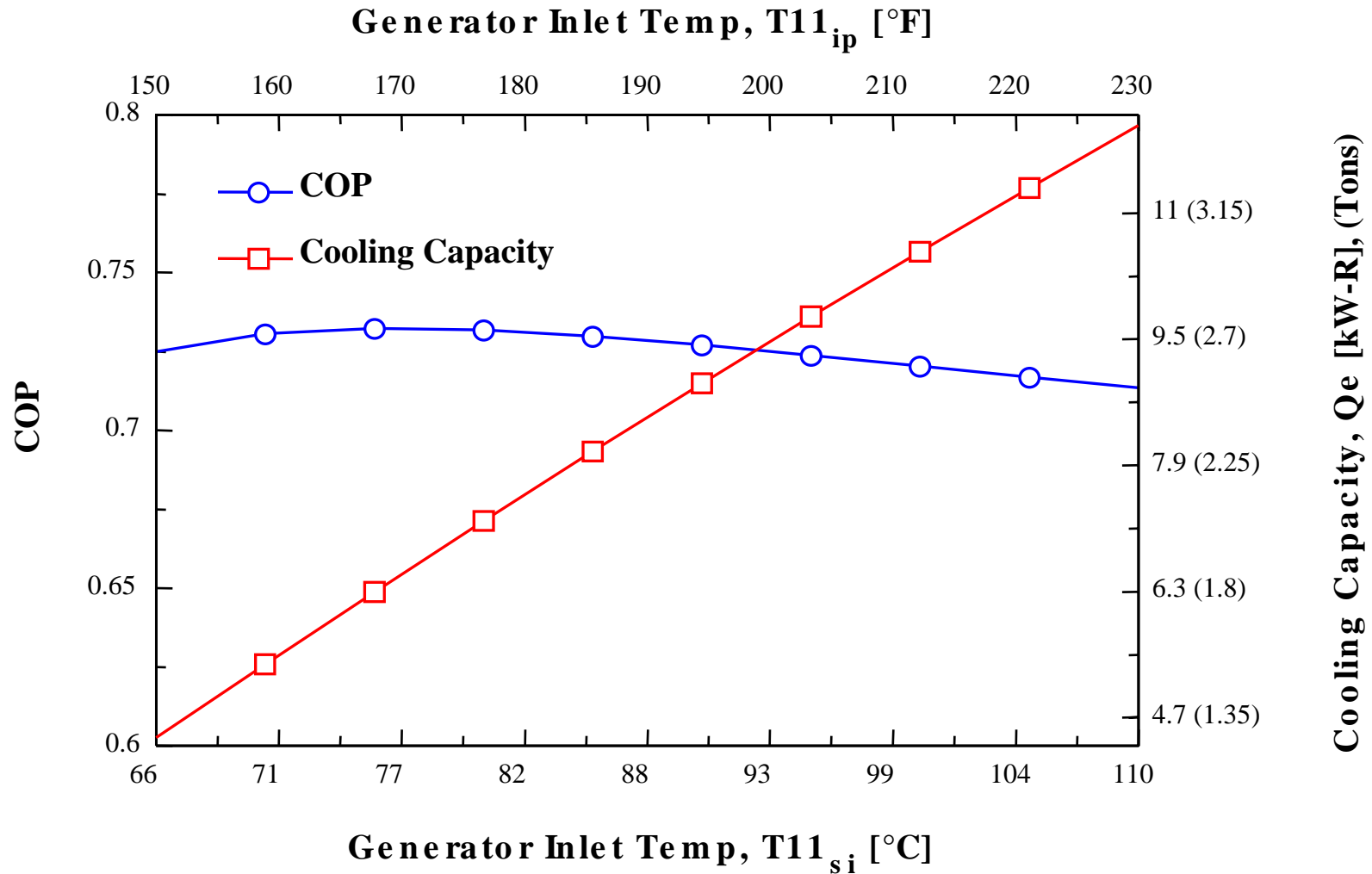

Absorption Chiller Performance Data

24-Hour Chiller Performance History for 29-Aug-2001

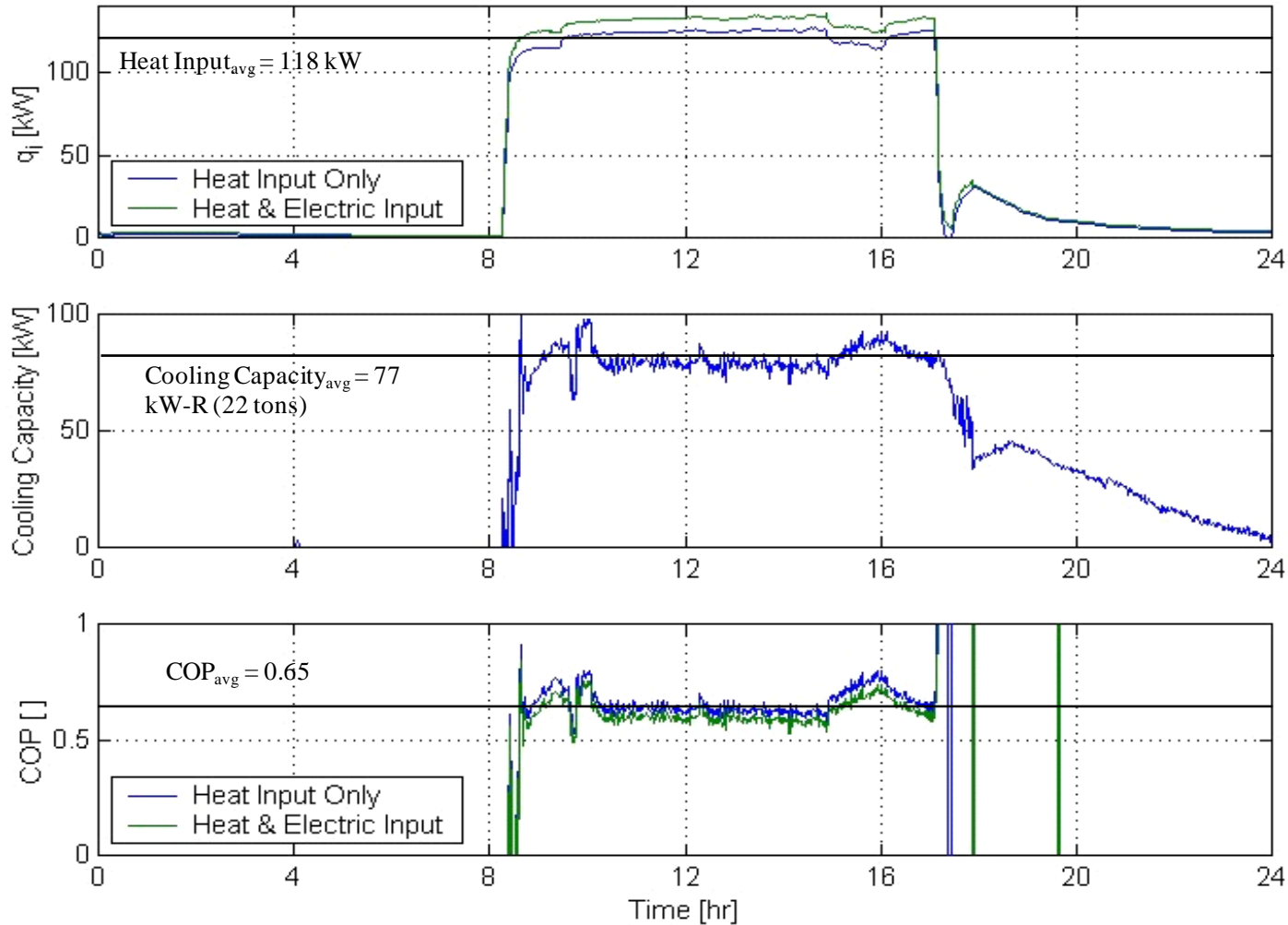

Multi Stage Cycles-Definitions

- ***Basic cycle***: single-stage absorption cycle
- ***Exchange unit***: heat exchanger for heat and mass exchange
- ***Number of stages***: minimum number of basic cycles that are combined.
- ***Number of effects***: number of times a certain amount of heat is reused between exchange units by internal heat exchangers
- ***Cascade***: assembly of cycles coupled by heat transfer only
- ***Machine***: compressor or work producing device

Rules for Combination of Basic Cycles

- At least ***one exchange unit*** of any basic cycle must be connected by ***heat and/or mass exchange*** with an exchange unit of the original configuration
- ***An exchange unit or machine*** can belong to more than one basic cycle
- ***Any combination*** of exchange units and machines ***must be decomposable*** into basic cycles
- Within a basic cycle the ***direction and flow rate*** of the working fluid can be chosen ***independently***
- The ***maximum number of independent streams*** equals the ***number of basic cycles***

Rules for Combination of Basic Cycles

- ***An exchange unit can be eliminated*** when it belongs to more than one basic cycle and when the heat exchange and flow rates cancel each other.
- ***Independent working fluid streams can be selected*** such that complete internal heat exchange is possible. The number of external temperature levels is reduced.
- ***All (S+1)-stage configuration*** can be created by adding ***basic cycle*** to an ***S-stage configuration***.
- The new configuration has ***from 1 to 4 exchange units*** in common with the added basic cycle.

Two-Stage Cycles

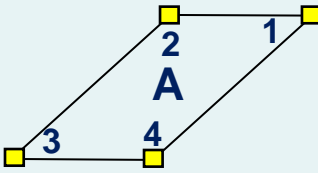
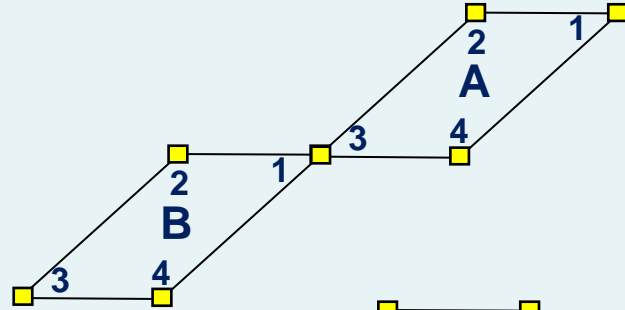
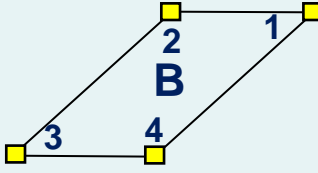
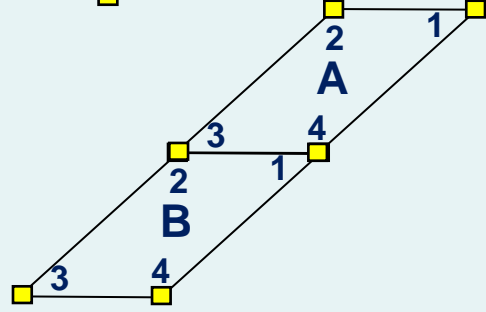
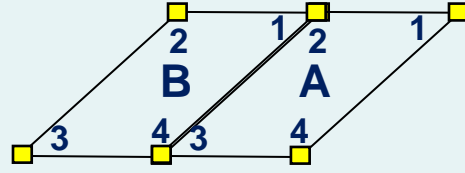
Basic Cycle	Two-Stage Cycles
	<p data-bbox="772 600 903 641">A3-B1</p> 
	<p data-bbox="772 852 1144 893">A3-B2 and A4-B1</p> 
	<p data-bbox="772 1185 1144 1226">A2-B1 and A3-B4</p> 

Multi-Stage Cycles – H₂O / LiBr

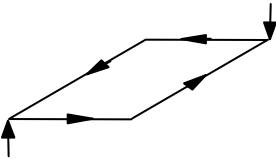
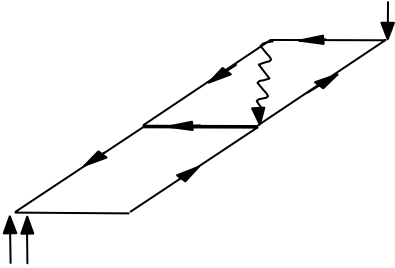
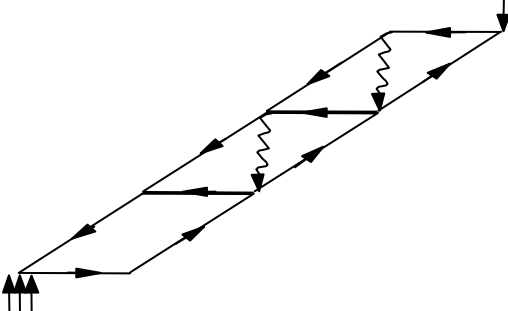
CYCLE #	DESCRIPTION	BLOCK DIAGRAM
A1	Single-Stage, Single-Effect	
A2	Two-Stage, Double-Effect	
A3	Three-Stage, Triple Effect	

Multi-Stage Cycles – NH₃ / H₂O

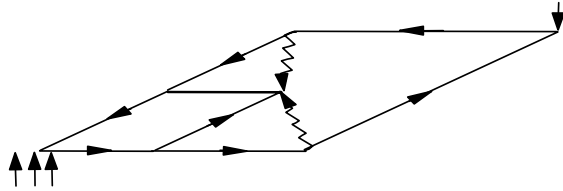
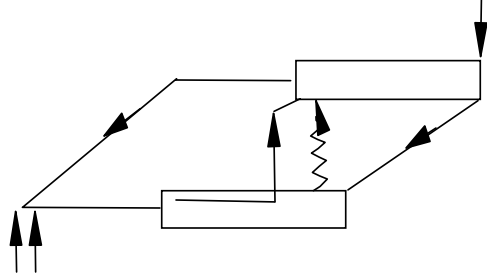
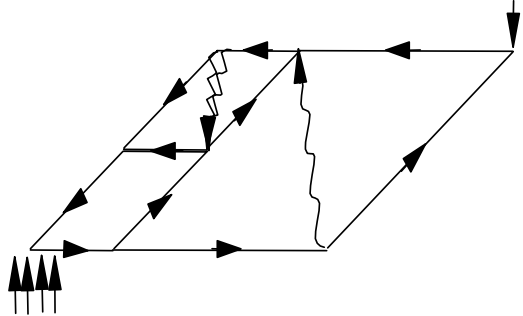
CYCLE #	DESCRIPTION	BLOCK DIAGRAM
B1	Desorber-Absorber HX	
B2	Two-Stage, Triple-Effect	
B3	Three-Stage, Quadruple Effect	

Multi-Stage Cycles – LiBr/H₂O - NH₃/H₂O

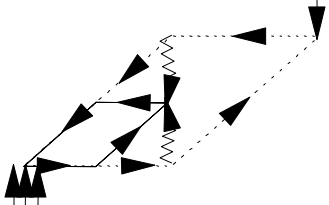
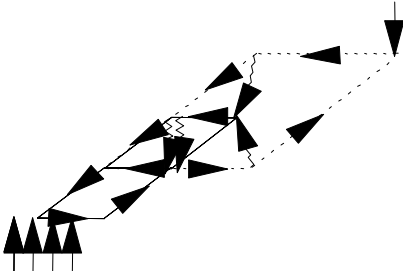
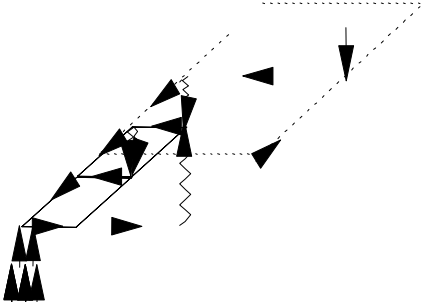
CYCLE #	DESCRIPTION	BLOCK DIAGRAM
C1	<p>Single-Stage Water-LiBr Cycle Cascaded with a Single-Stage Ammonia-Water Cycle For a Triple Effect System</p>	
C2	<p>Two-Stage Water-LiBr Cycle Cascaded with a Single-Stage Ammonia-Water Cycle For a Quadruple Effect System</p>	
C3	<p>Two-Stage Water-LiBr Cycle Cascaded with a Single-Stage Ammonia-Water Cycle For a Quintuple Effect Systems</p>	

Multi-Stage Cycles – LiBr/H₂O - NH₃/H₂O

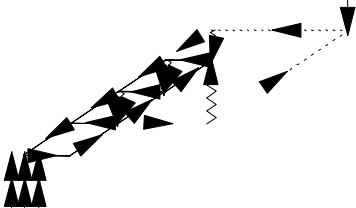
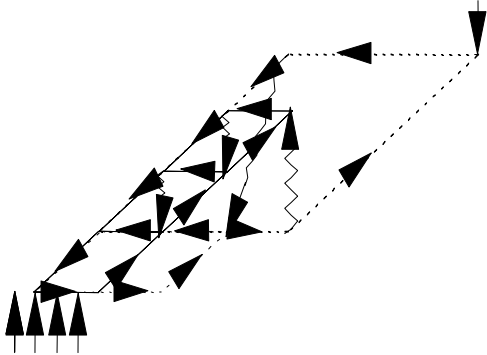
CYCLE #	DESCRIPTION	BLOCK DIAGRAM
C4	<p>Three-Stage Water-LiBr Cycle Cascaded with a Single-Stage Ammonia-Water Cycle For a Sextuple Effect System</p>	
C5	<p>Three-Stage Water-LiBr Cycle Cascaded with Two Single-Stage Ammonia-Water Cycle For a Quadruple Effect System</p>	

LEGEND

————— Water / LiBr Cycle

..... Ammonia / Water Cycle

Multi-Stage Cycles

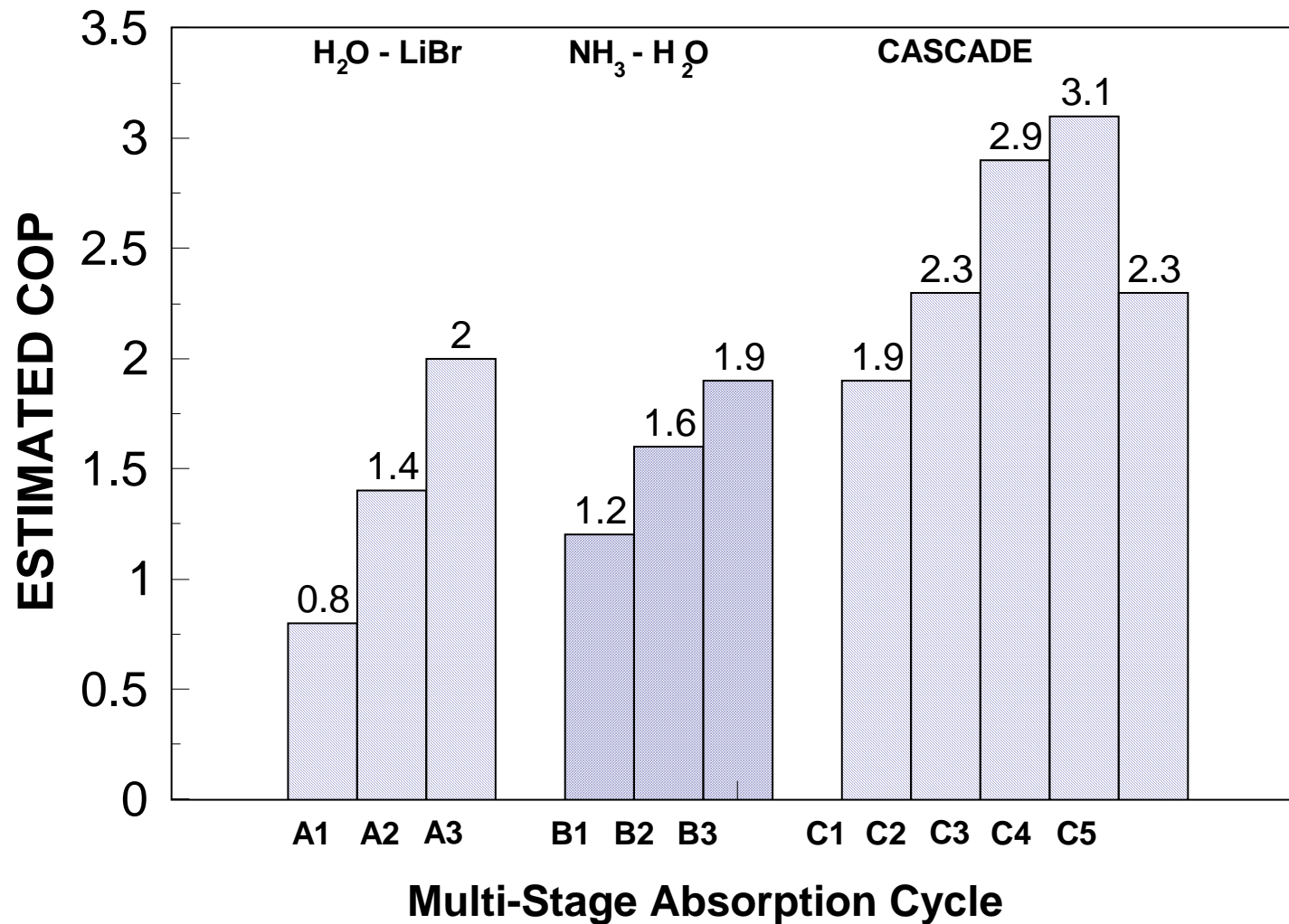

Multi-Stage Cycles

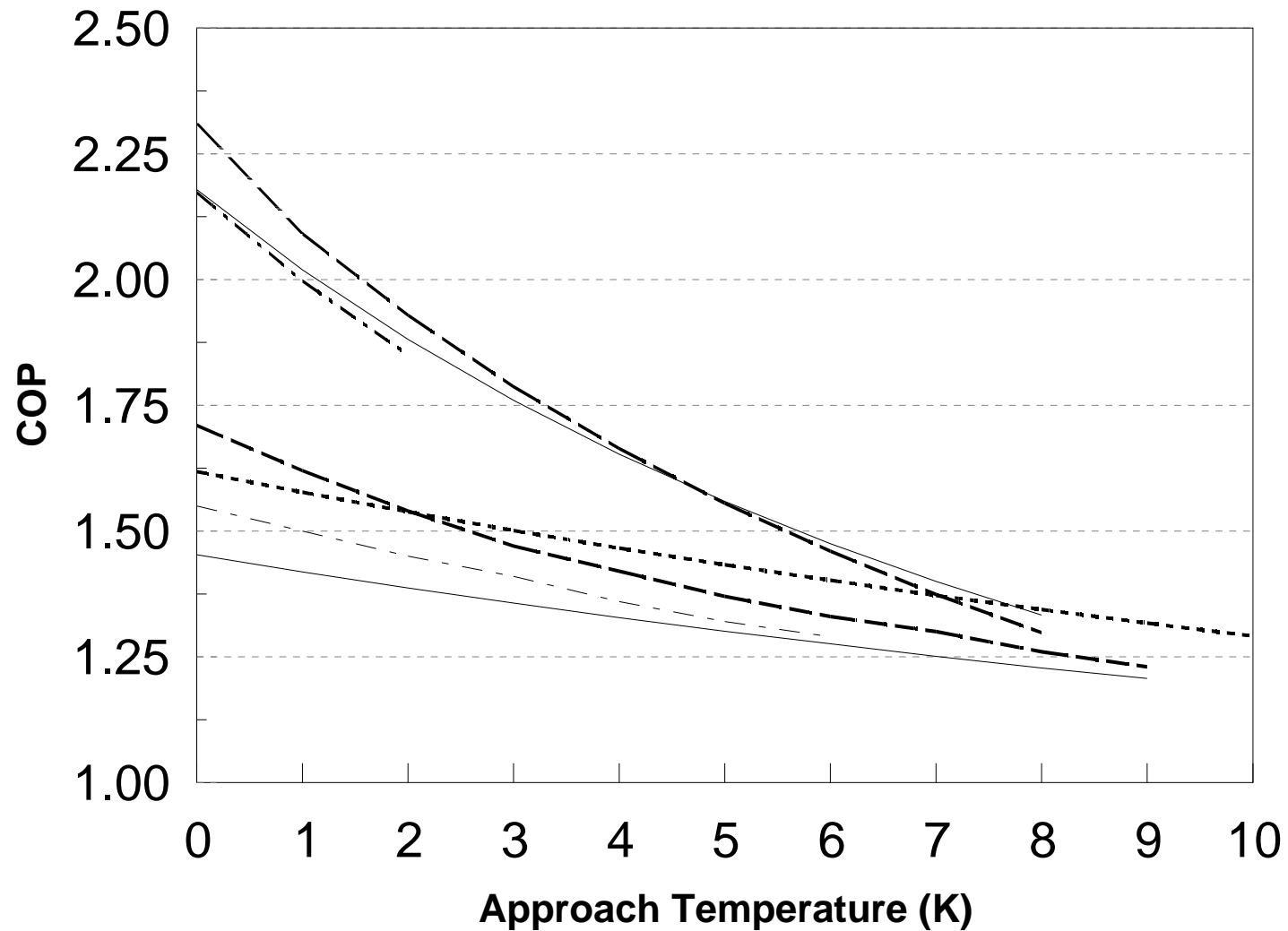

Multi Effect Absorption Cycles

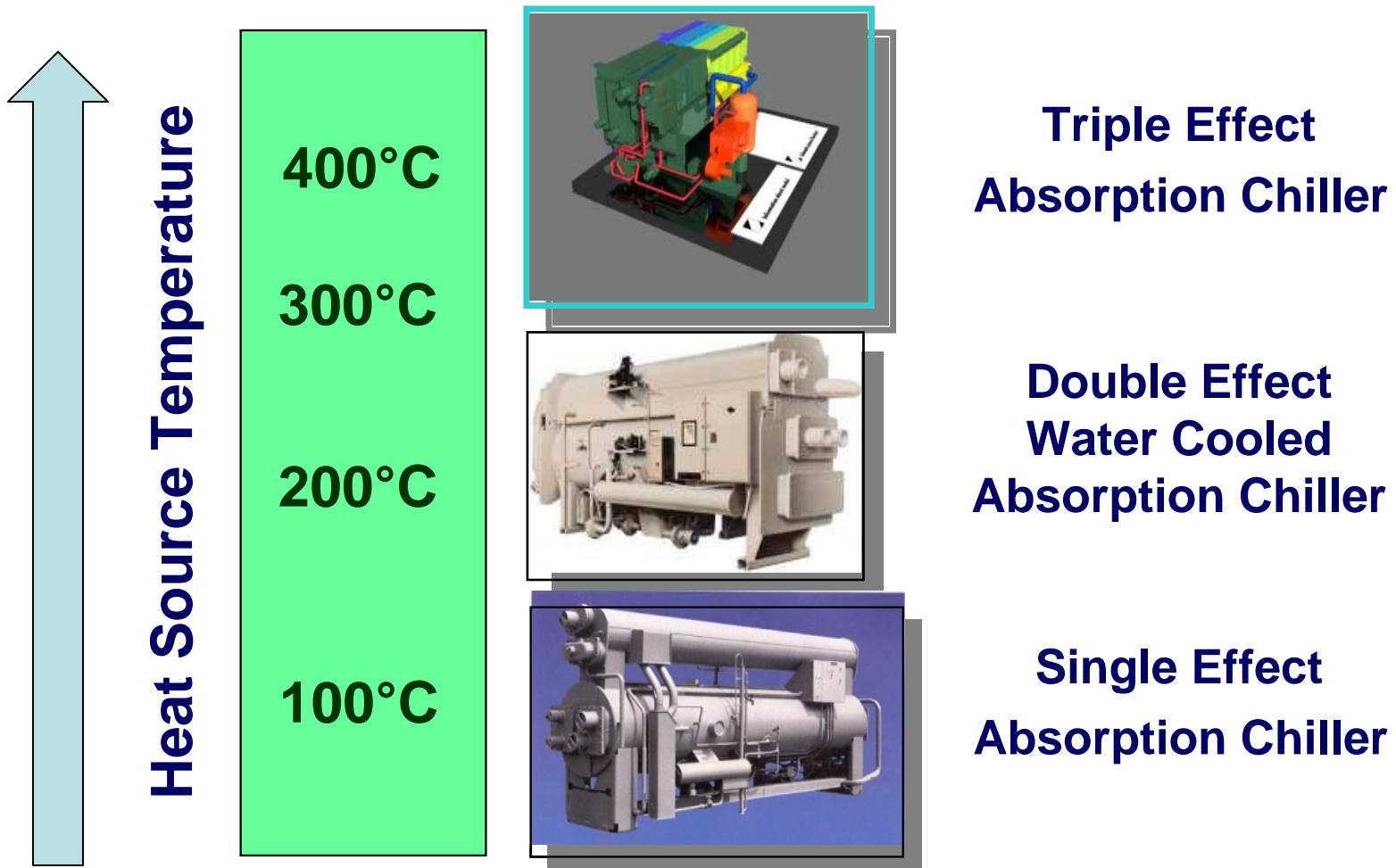

Typical Performance of Absorption Cycles

Type	COP	Heat Source Temperature [° C]	Type of Solar Collectors Matched
Single-effect	0.7	85 (60 – 110)	Flat-plate
Double-effect	1.2	130 (130 – 165)	Flat-plate/Compound Parabolic Concentrator
Triple-effect	1.7	220	Evacuated-tube/Concentrating

Absorption Systems: GRI

- American Yazaki
 - Broad Air Conditioning
 - Carrier Corporation
 - Dunham-Bush Inc.
 - Energy Concept
 - McQuay International
 - Robur Corporation
 - Trane Company
 - York International
- Single effect
 - Double effect
 - Triple effect

Absorption Cycle Solar Cooling System

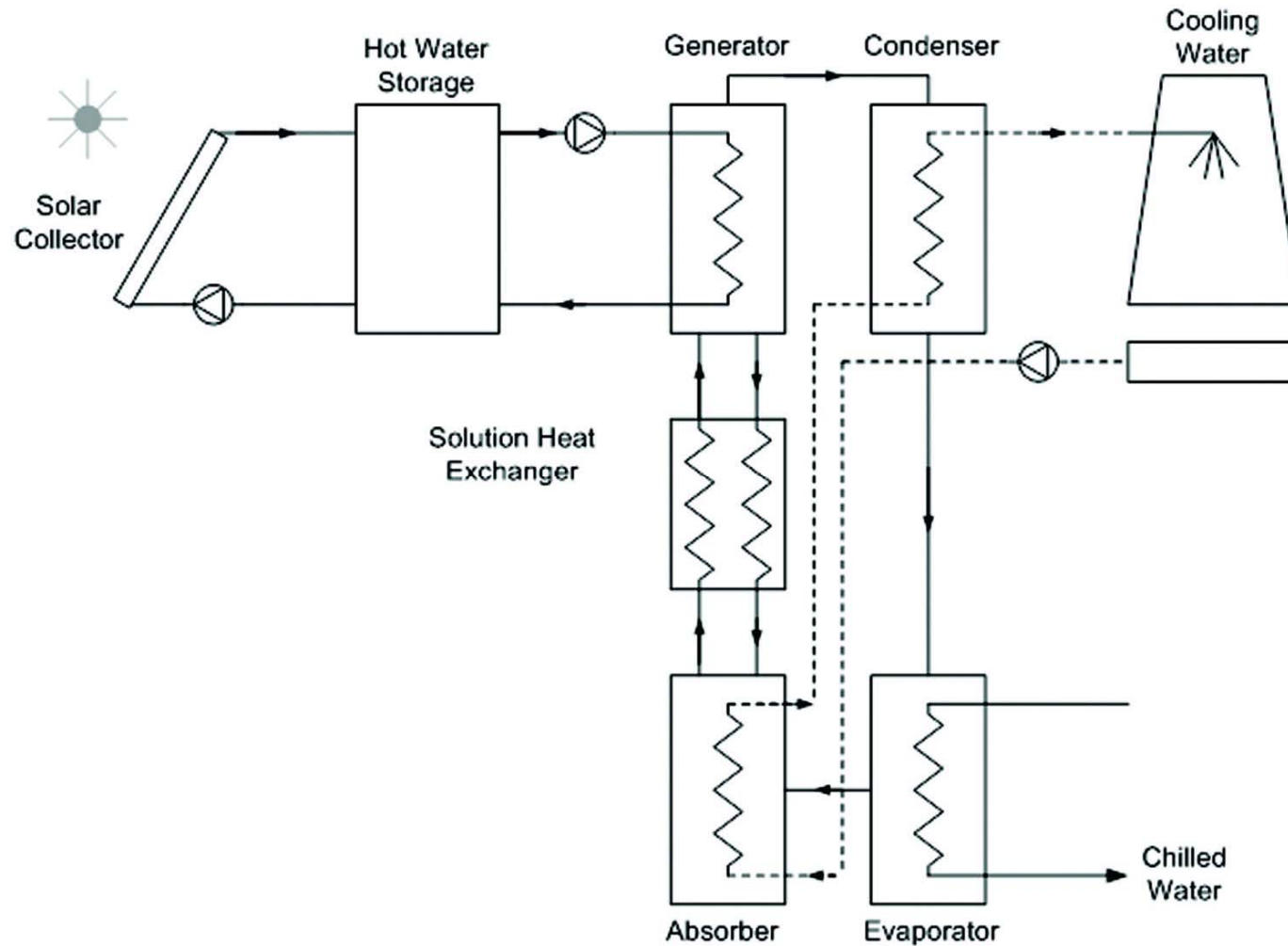

Absorption System: Energy Concept



- **ISAAC Solar Icemaker, installed at Abu Simbel, Egypt 2002**
- **54 kg ice per day from 12m² solar thermal collector (intermittent cycle)**

Questions?



- Yunho Hwang
- Email: yhhwang@umd.edu